

SE-CV-12V-100W

SE-CV-12V-100W

Non Dimmable

## Product Features

Selectable constant current and constant voltage output.(Custom on request)

Full-ioslated,delivering up to 80W of power

Short circuit,over current and over voltage protection

Fireproof environmental protection PC plastic cover

In line with the world lighting safety standards

5 years quality warranty



## Electrical specifications

Input	Voltage range	90-130V/AC&180-240V/AC					
	Frequency range	50-60Hz					
	Power factor	>0.95					
	Full load eciency	≥85%					
	AC Current	1.02A&0.51A					
Output	Output mode	Constant Voltage					
	Rated current		7A		4.2A		
	Current accuracy		± 10%		± 10%		
	Output voltage range		12V		24V		
	Rated power	100W					
保护 Protect	Short circuit protection	Intermittent restart mode,after the exception can be automatically restored					
	Over current protection	Hiccup mode,after the removal of abnormalow can be automatically restored					
	Over voltage protection	Hiccup mode,after the exception of abnormal pressure can be automatically restored					

Non Dimmable

Environment	Operating Temperature/humidity	-30-45°C,5-95%RH
	Storage Temperature/humidity	-40-70°C,5-95%RH
	Temperature coefficient	±0.03%/°C(0-50°C)
	Vibration	5-55Hz/2g,30 Minutes
EMC Safety	Safety	EN60598
	Pressure	I/P-O/P:3KVAC IP-FG:1.88KVAC O/P-FG:0.5KVAC
	Insulation resistance	I/P-O/P I/P-FG O/P-FG:100MΩ/500VDC/25°C/70%RH
	EMC Emission	EN55022,EN55015 Class B
Other	EMC Immunity	EN61547,ENV5024,EN61000-4-2/3/4/6/8/11
	Net weight	370g
	Size	170*50*31mm

Shell structure

Units:mm

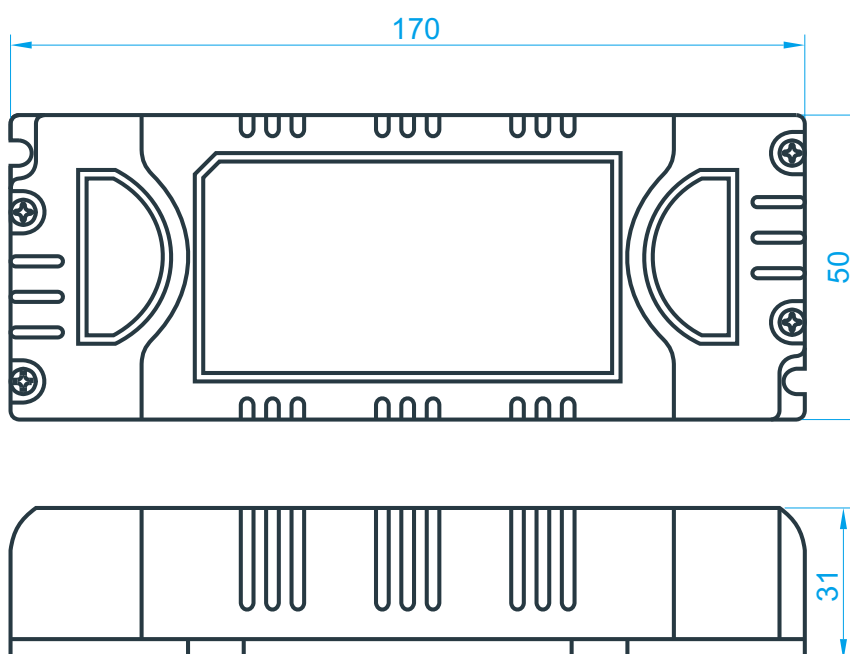

Triac dimmer wiring diagram

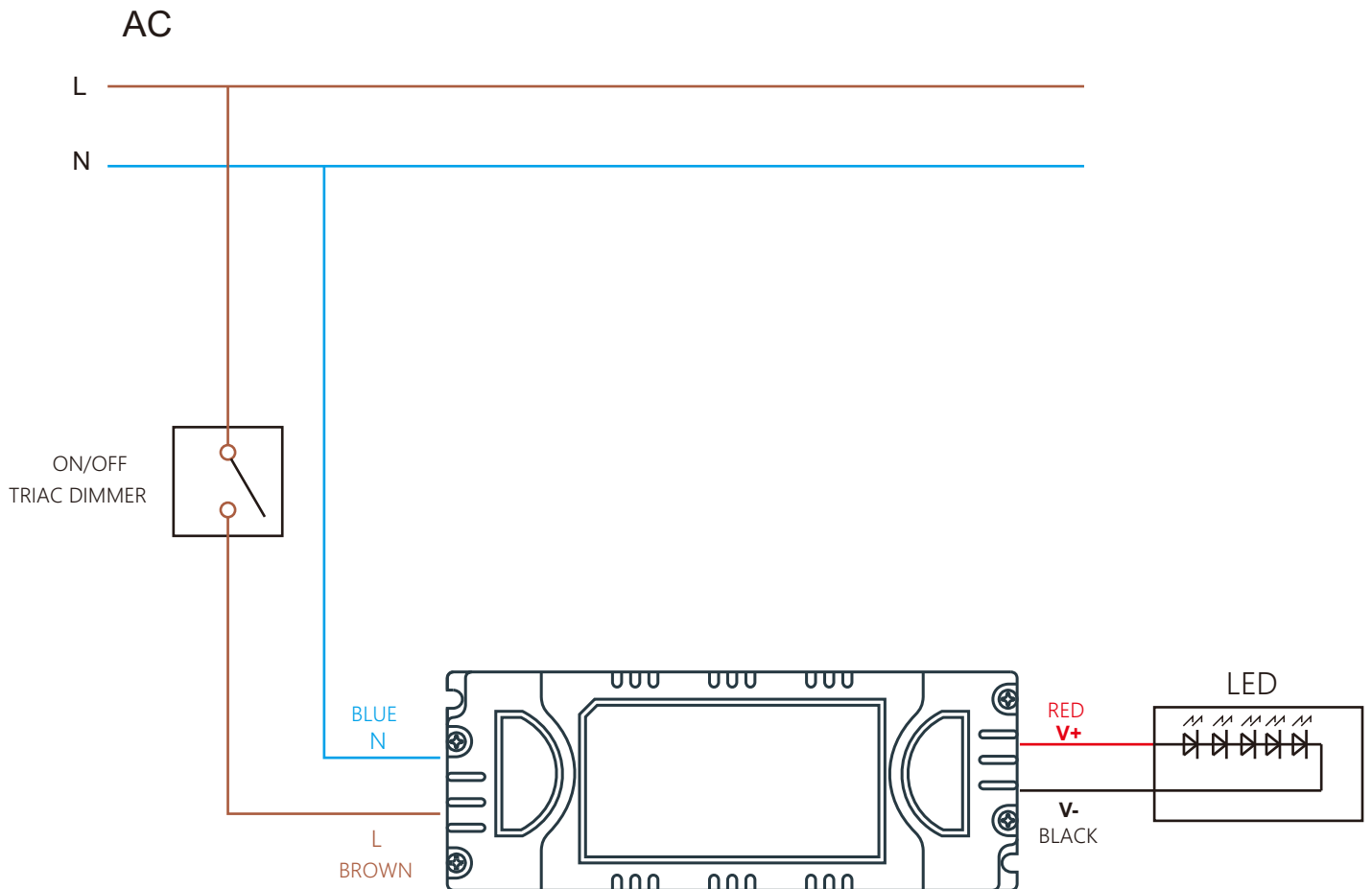

Packing

