

Product Features

Selectable constant current and constant voltage output.(Custom on request)

Full-ioslated,delivering up to 60W of power.

Short circuit,over current and over voltage protection.

Fireproof environmental protection PC plastic cover

In line with the world lighting safety standards

5 years quality warranty



Electrical specifications



Input	Voltage range	90-130&180-240V/AC					
	Frequency range	50-60Hz					
	Power factor	>0.95					
	Full load efficiency	≥85%					
	AC current	0.64A/0.32A					
Output	Rated current	Constant Current				Constant Voltage	
	Rated current	900mA	1200mA	1500mA	1800mA	4000mA	2500mA
	Current accuracy	±5%	±5%	±5%	±5%	±10%	±10%
	Output voltage range	46-66V	35-50V	28-40V	23-33V	12V	24V
	Rated pwer	60W					
protect	Short circuit protection	Intermittent restart mode, after the exception can be automatically restored					
	Overcurrent protection	Hiccup mode, after the removal of abnormal flow can be automatically restored					
	Overvoltage protection	Hiccup mode, after the exception of abnormal pressure can be automatically restored					

Triac Dimmable

Environment	Operating Temperature/humidity	-30- 45°C,5- 95%RH
	Storage Temperature/humidity	-40- 70°C,5- 95%RH
	Temperature coefficient	± 0.03%/°C(0- 50°C)
	Vibration	5- 55Hz/2g,30 Minutes
EMC Safety	Safety	EN60598
	Pressure	I/P- O/P:3KVAC IP- FG:1.88KVAC O/P-FG:0.5KVAC
	Insulation resistance	I/P- O/P I/P- FG O/P- FG:100M Ω /500VDC/25°C/70%RH
	EMC Emission	EN55022,EN55015 Class B
Other	EMC Immunity	EN61547,ENV5024,EN61000-4-2/3/4/6/8/11
	Net weight	250g
	Size	133*46*29mm

Shell structure

Units:mm

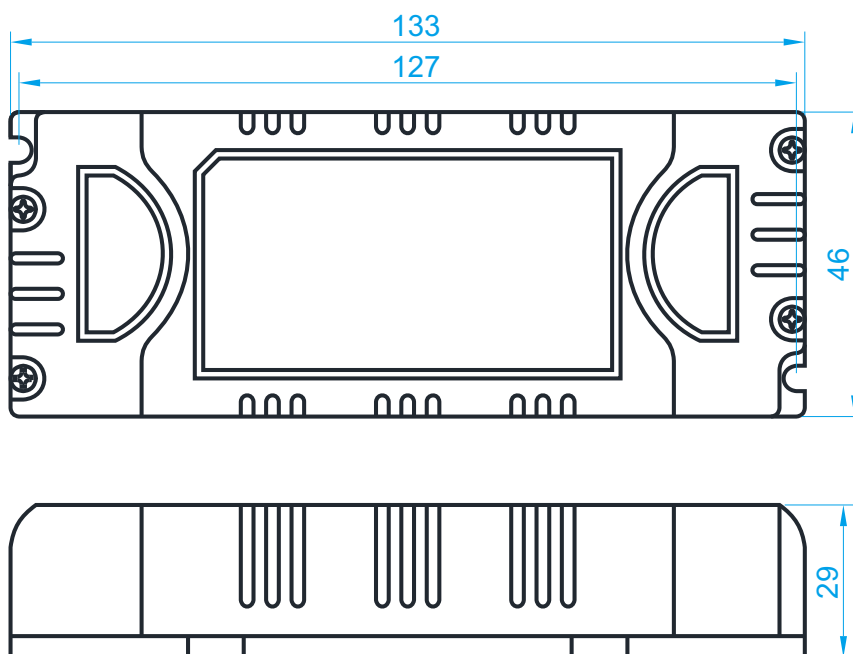

Triac dimmer wiring diagram

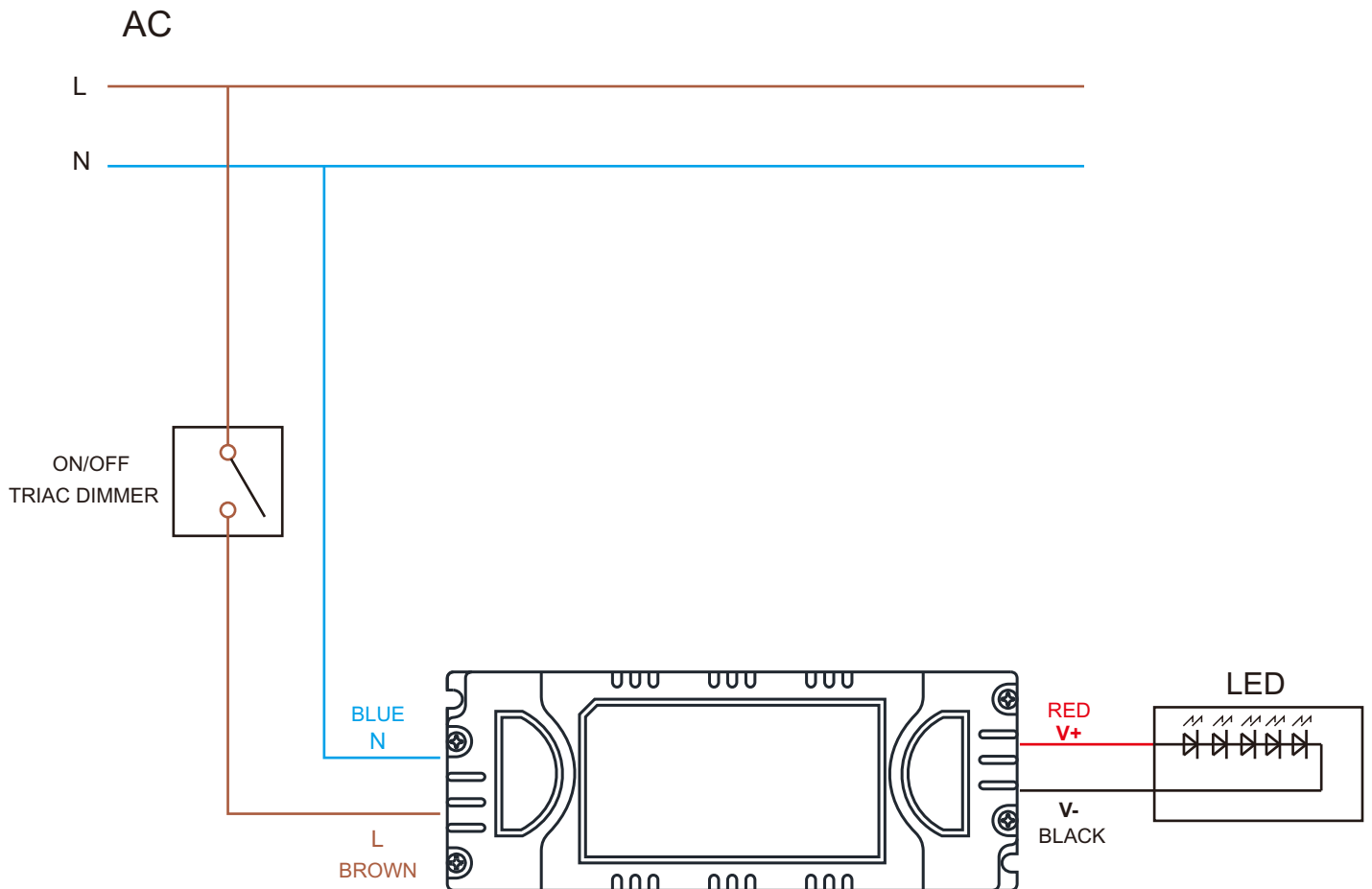

Packing

