

PIR SENSOR SE-RT26

Product Features

Hole: 12mm cut out

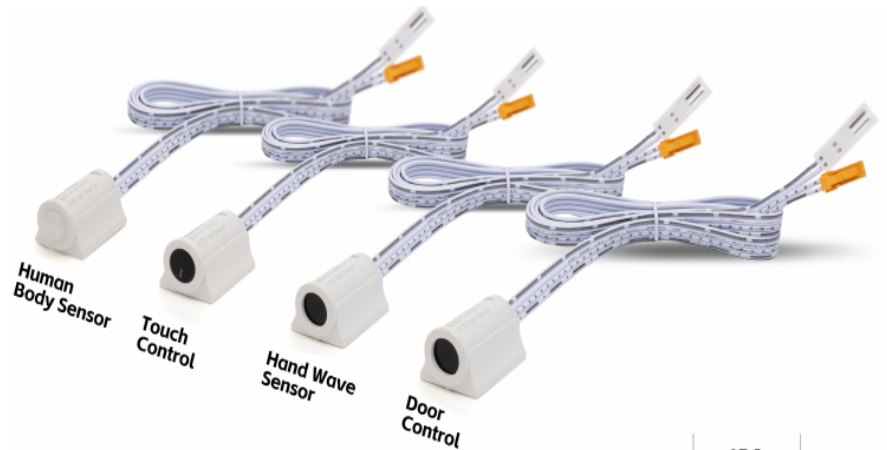

Voltage: DC 5-24V
Load: DC 5A
5V 25W / 12V 60W / 24V 120W

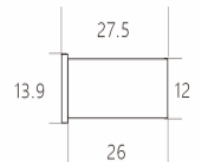

Product Wiring Diagram

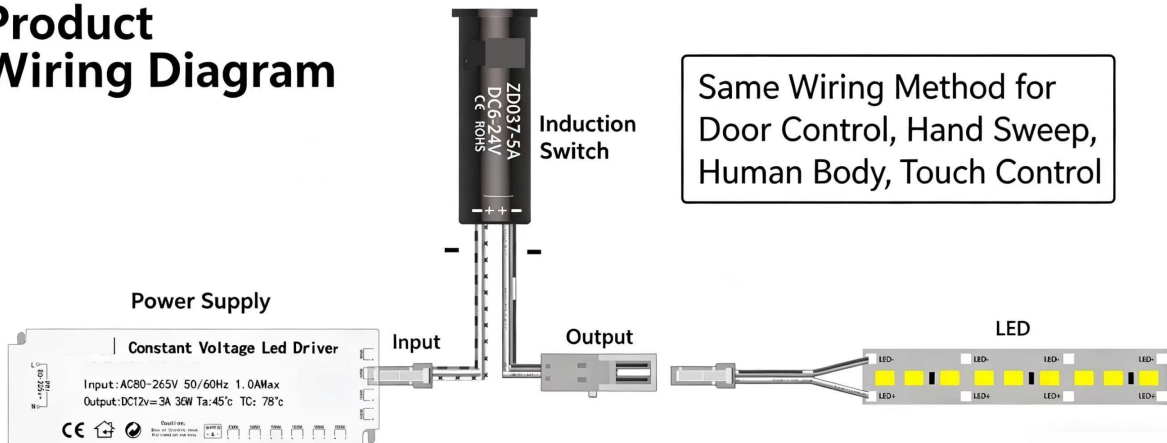

Connect Transformer

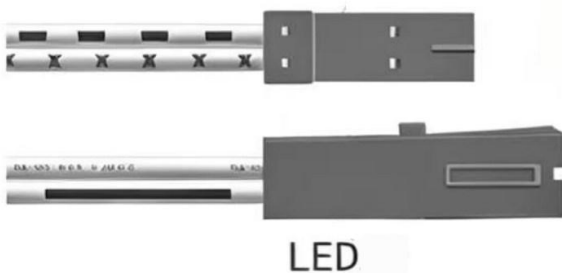

Wire Input/Output + - Pole Instructions



* The information in this datasheet may be changed by Everglow Lighting at any time without prior notice.

External Mounting Instruction

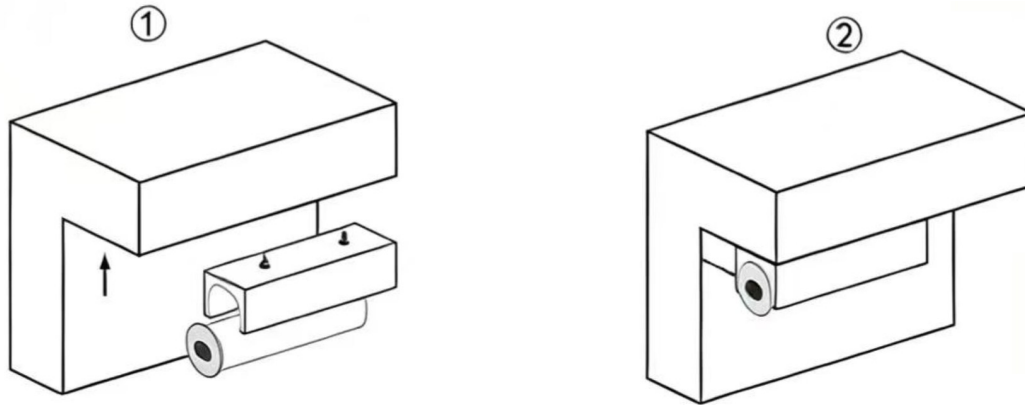

Embedded Mounting

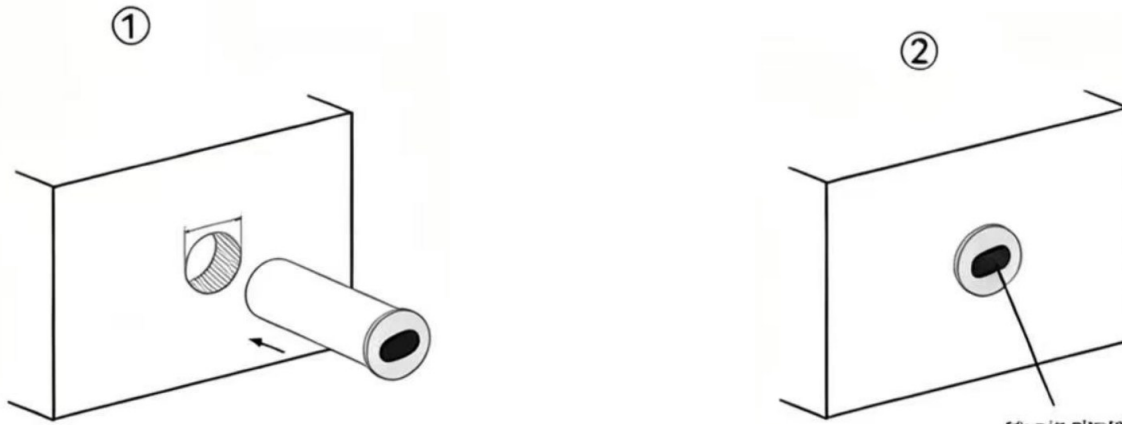

Connection Demonstration

