

SE-CV-12V-150W

SE-CV-24V-150W

Non Dimmable

Product Features

Selectable constant current and constant voltage output.(Custom on request)

Full-isolated,delivering up to 150W of power.

Short circuit,over current and over voltage protection

Fireproof environmental protection PC plastic cover

In line with the world lighting safety standards

5 years quality warranty

SE-CV-12V-150W
SE-CV-24V-150W



Electrical specifications



Input	Voltage range	90-130V/AC&180-240V/AC					
	Frequency range	50-60Hz					
	Power factor	>0.95					
	Full load efficiency	≥85%					
	AC Current	1.02A&0.51A					
Output	Output mode	Constant Voltage					
	Rated current		10A		6.25A		
	Current accuracy		± 10%		± 10%		
	Output voltage range		12V		24V		
	Rated power	150W					
Protect	Short circuit protection	Intermittent restart mode,after the exception can be automatically restored					
	Over current protection	Hiccup mode,after the removal of abnormal low can be automatically restored					
	Over voltage protection	Hiccup mode,after the exception of abnormal pressure can be automatically restored					

Non Dimmable

Environment	Operating Temperature/humidity	-30-45°C,5-95%RH
	Storage Temperature/humidity	-40-70°C,5-95%RH
	Temperature coefficient	±0.03%/°C(0-50°C)
	Vibration	5-55Hz/2g,30 Minutes
EMC Safety	Safety	EN60598
	Pressure	I/P-O/P:3KVAC IP-FG:1.88KVAC O/P-FG:0.5KVAC
	Insulation resistance	I/P-O/P I/P-FG O/P-FG:100MΩ/500VDC/25°C/70%RH
	EMC Emission	EN55022,EN55015 Class B
Other	EMC Immunity	EN61547,ENV5024,EN61000-4-2/3/4/6/8/11
	Net weight	370g
	Size	189*65*30mm

Shell structure

Units:mm

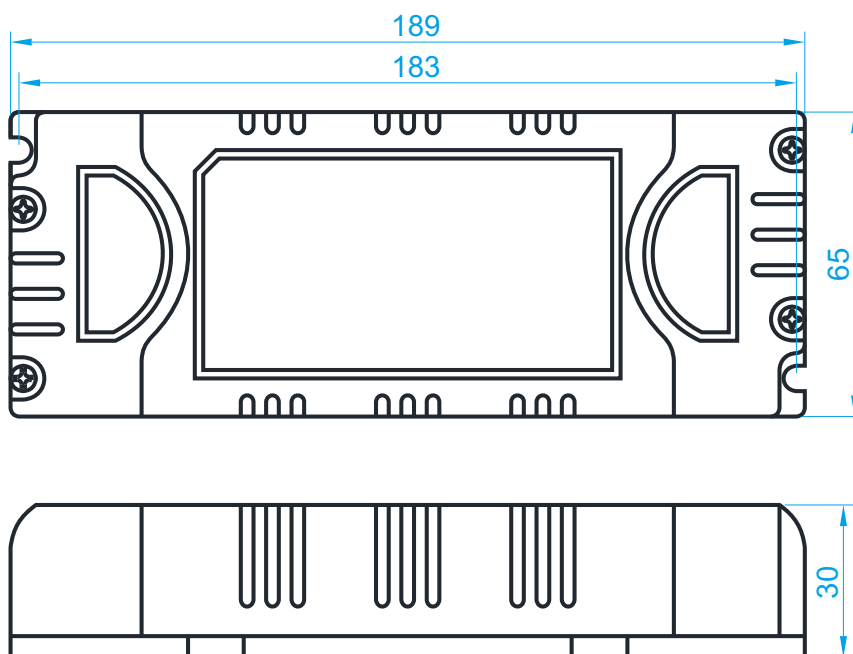

Triac dimmer wiring diagram

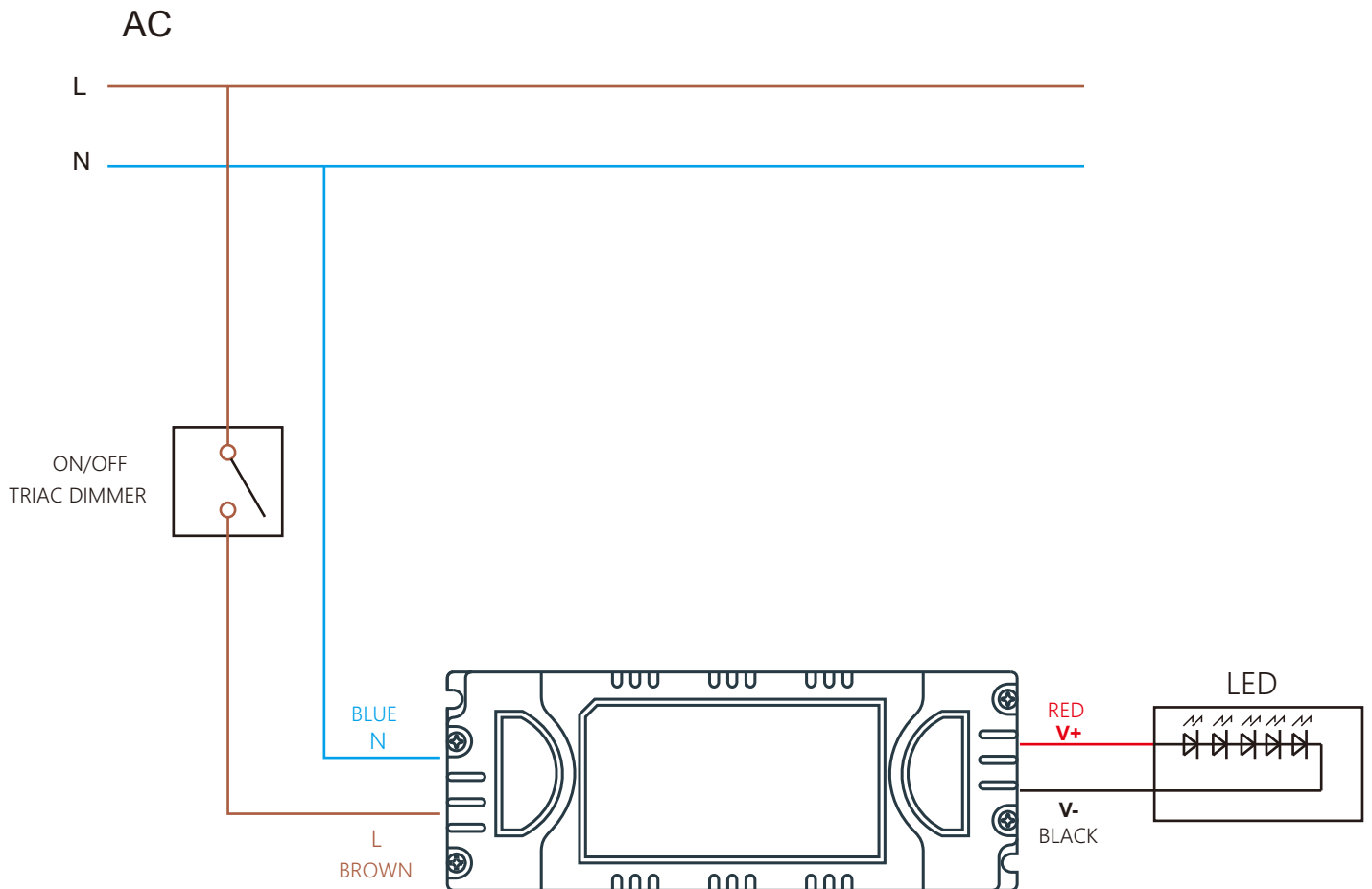

Packing

