

## 10/15/20W SELECTABLE LED WEATHER-PROOF SENSOR BATTEN

### Product Features

- High quality, robust polycarbonate diffuser
- Commercial grade quality and design
- Selectable power 10W, 15W and 20W with a DIP switch
- Integral constant current non-dimmable and flicker free LED driver
- Microwave motion sensor, setting by Dip switch or remote control

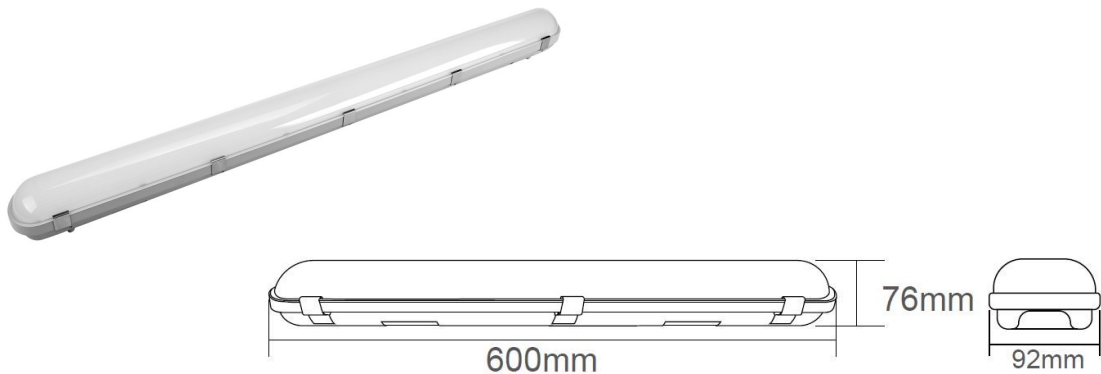

### Technical Specification

Model	SE-SP21-TC
Watts	10W-15W-20W
Input Voltage	AC 200-240V 50/60Hz
Colour Temp.	TRI Color: 3000K / 4000K / 6000K
Lumens Output	2200lm @20W
CRI	Ra>80
Beam Angle	120°
Size	600* 92*76mm
IP Grade	IP 65
Sensor	Microwave motion sensor, setting by Dip switch or remote control

# SENSOR SETTINGS

## 1. Automatically ON/OFF function



With sufficient daylight, even when motion detected, light remains OFF.



With insufficient daylight, the sensor turns light ON when motion gets detected.



The sensor turns OFF light automatically after the holdtime when there's no motion detected.

## 2. Daylight Disable

When daylight threshold is preset as "disable", the sensor turns light ON when motion gets detected, and OFF after hold-time.



The sensor turns light ON when motion gets detected.



The sensor keeps light ON for holdtime period after



The sensor turns OFF light automatically after the

## 3. Corridor Function, Bi-level Dimmable



With sufficient daylight, the sensor keeps light OFF even motion gets detected.



With insufficient daylight, the sensor turns light ON when motion gets detected.



After there's no motion detected, the sensor keeps light ON 100% for holdtime.



After holdtime, sensor dims light to standby dimming level for standby period.



The sensor turns OFF light automatically after the standby period when there's no motion detected.

## DIP Switch Setting

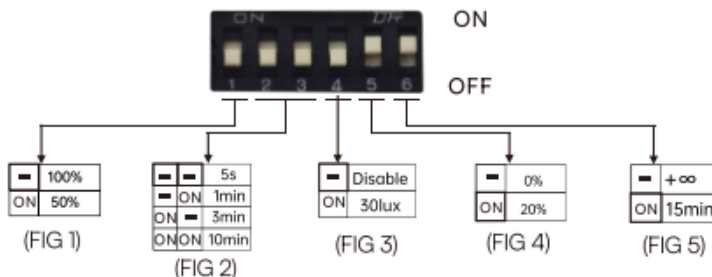

**Detection Area** - It can be adjusted by combining DIP switches for specific application [FIG 1].

**Hold Time** - Time period during which the light will be ON after the last detection [FIG 2].

**Daylight Threshold** - Daylight sensor priors motion sensor. Set Threshold for Specific needs. If disabled, only motion sensor will work [FIG 3].

**Stand-by dimming level** - The dimming level during which the light is ON during the stand-by Period [FIG 4].

**Stand-by Period** - This is the time period during which the light keeps dimming down after the last detection [FIG 5].

### Default Setting:

Detection Area 100%, Hold Time 5s, Daylight Threshold Disable, Stand-by dimming level 20%, Standby Period 15min